

AVERY DENNISON MARKETING SPECIFICATION

THE SUBJECT MATTER DISCLOSED HEREIN EMBODIES PROPRIETARY INFORMATION WHICH IS THE CONFIDENTIAL PROPERTY OF THE AVERY DENNISON CO. NONE OF WHICH SHALL BE COPIED, REPRODUCED, DISCLOSED TO OTHERS, PUBLISHED OR USED IN WHOLE OR IN PART, FOR ANY PURPOSE OTHER THAN THAT FOR WHICH IT IS BEING MADE AVAILABLE WITHOUT THE EXPRESS ADVANCE WRITTEN PERMISSION OF A DULY AUTHORIZED AGENT OF THE COMPANY. THIS DOCUMENT IS THE PROPERTY OF THE AVERY DENNISON CO. AND IS TO BE RETURNED TO THE COMPANY ON DEMAND.

HISTORY

REV.	DATE	DESCRIPTION
A	2/17/15	RELEASE

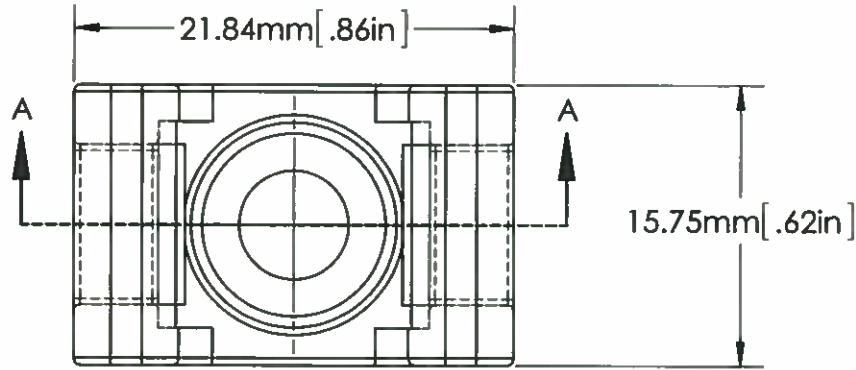

SCALE 4 : 1

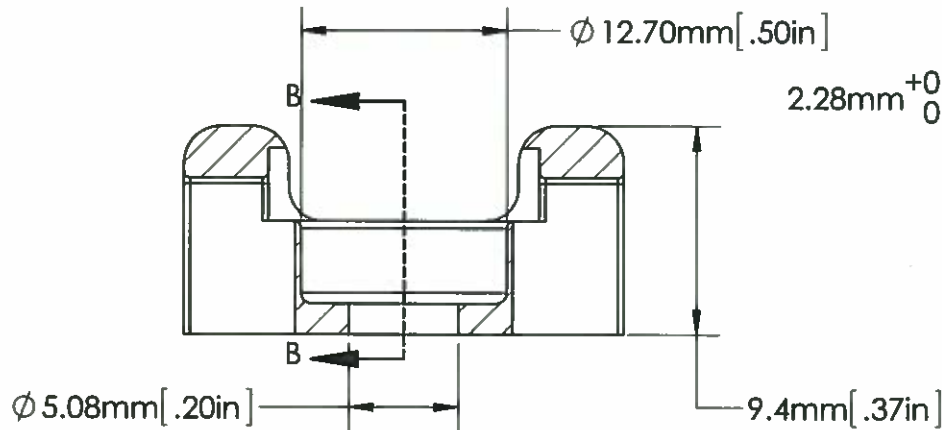

SECTION A-A
SCALE 4 : 1

$2.28\text{mm} \begin{matrix} +0.76 \\ 0 \end{matrix} \left[\begin{matrix} .090 \\ .090 \end{matrix} \begin{matrix} +.030 \\ -.000 \end{matrix} \right]$

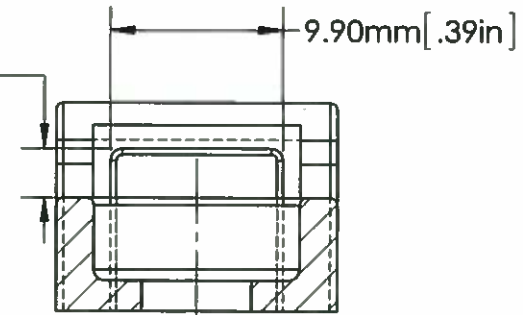

SECTION B-B
SCALE 4 : 1



APPROVALS: ENG. APPR. *[Signature]* 2-17-15
Q.A. APPR. *[Signature]* 2-23-15

AVERY DENNISON
FASTENER DIVISION
FITCHBURG, MA 01420 U.S.A.
TEL. 1-800-225-5913
FAX. 978-353-8157

WEIGHT:	.071 oz./2.02 grams	SPECIFIED TOLERANCES ARE: .XX ± .03 INCHES .XX ± .25 MM ANGULAR: ± 2°	MATERIAL	NYLON 6/6	DESCRIPTION	CRADLE MOUNT, HEAVY DUTY		
MOUNTING:	# 10 (FLATHEAD SCREW)		COLOR	NATURAL	STOCK NO.	10046-2	REV.	A
PACKAGING:	100/BAG, 5000/CASE							