

AVERY DENNISON MARKETING SPECIFICATION

HISTORY

REV.	DATE	DESCRIPTION
L	10.29.14	REDRAWN IN NEW FORMAT, ADDED UL INFORMATION AND LOGO

THE SUBJECT MATTER DISCLOSED HEREIN EMBODIES PROPRIETARY INFORMATION WHICH IS THE CONFIDENTIAL PROPERTY OF THE AVERY DENNISON CO. NONE OF WHICH SHALL BE COPIED, REPRODUCED, DISCLOSED TO OTHERS, PUBLISHED OR USED IN WHOLE OR IN PART, FOR ANY PURPOSE OTHER THAN THAT FOR WHICH IT IS BEING MADE AVAILABLE WITHOUT THE EXPRESS ADVANCE WRITTEN PERMISSION OF A DULY AUTHORIZED AGENT OF THE COMPANY. THIS DOCUMENT IS THE PROPERTY OF THE AVERY DENNISON CO. AND IS TO BE RETURNED TO THE COMPANY ON DEMAND.

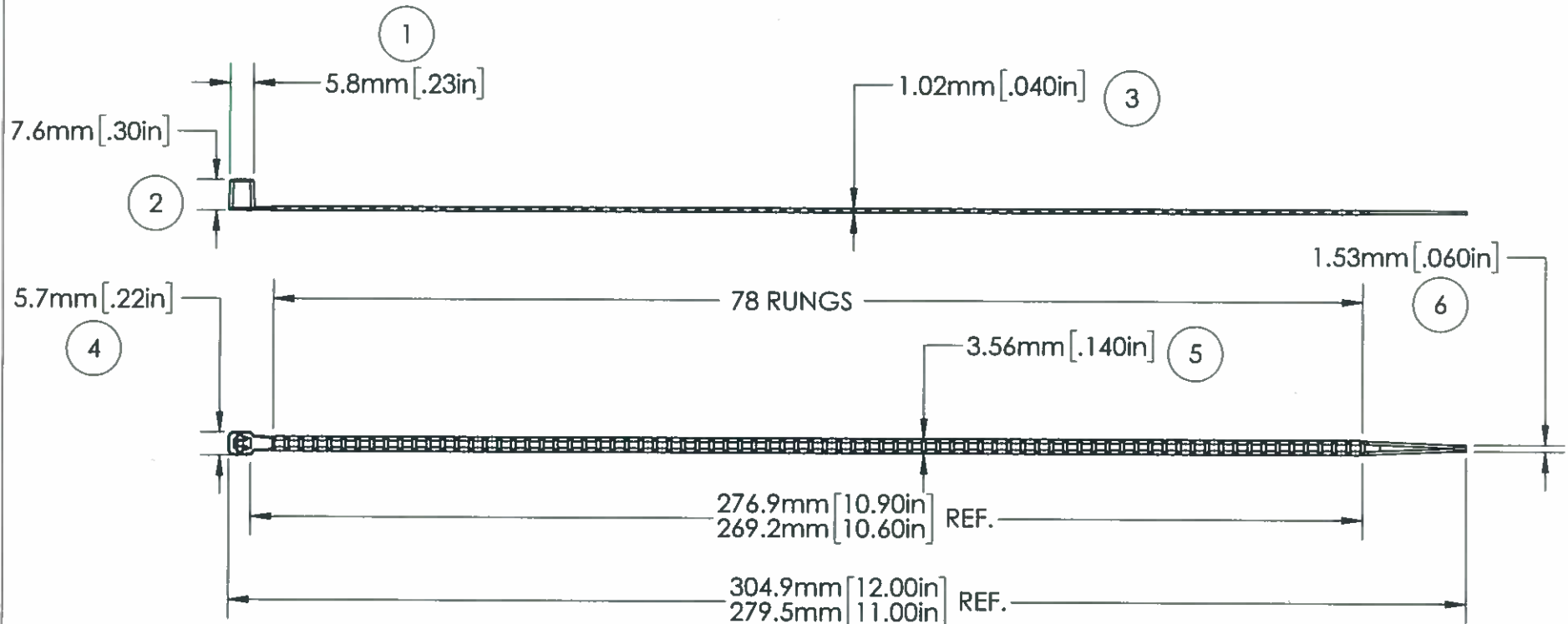

NOTE: THESE CABLE TIES ARE PLENUM RATED AND HAVE A FLAMMABILITY RATING OF V-2



LOOP TENSILE STRENGTH:	40 LBF/180 N MIN. PER AS-23190	APPROVALS:	ENG. APPR.	<i>M. O. d.</i> 7/26/2017	AVERY DENNISON <small>FASTENER DIVISION FRIBURG, MA 01420 U.S.A. TEL: 1-800-225-5913 FAX: 978-353-8157</small>	
OPERATING TEMP RANGE:	-40°F (-40°C) TO 221°F (105°C)		Q.A. APPR.	<i>J. Boyle</i> 7/26/2017		
MIN. INSTALLATION TEMP:	32°F (0°C)					
WEIGHT:	0.72 g. / (0.02448 oz.)	SPECIFIED TOLERANCES ARE:	MATERIAL	NYLON 6/6, HEAT STABILIZED	DESCRIPTION	
BUNDLE DIAMETER:	Ø 1.6mm TO Ø 76.2mm (0.06" - 3.0")		.XX ± .03 INCHES .X ± .7 MM	COLOR	BLACK	11" CABLE TIE, LADDER
TOOL:	12001-0 - HAND TOOL 12500-0 - PNEUMATIC TOOL	.XXX ± .010 INCHES .XX ± .25 MM			STOCK NO.	
PACKAGING:	100/BAG, 5000/CASE	ANGULAR: ± 2°			08479-0	REV. L

5

4

3

2

1