

AVERY DENNISON MARKETING SPECIFICATION

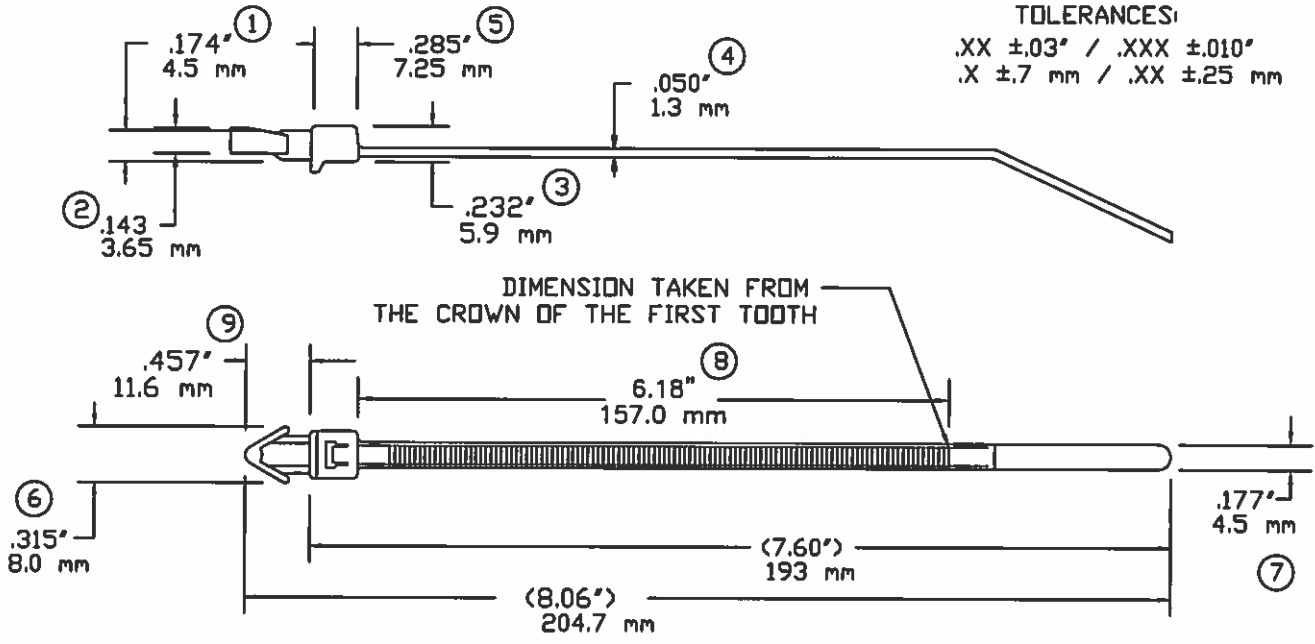

TOLERANCES:
 .XX ±.03" / .XXX ±.010"
 .X ±.7 mm / .XX ±.25 mm

NOT TO SCALE

LOOPED TENSILE STRENGTH:	50 LBF. / 220N MIN. PER AS-23190
MATERIAL:	NYLON 6/6 - BLACK HEAT STABILIZED
OPERATING TEMPERATURE:	-40°F (-40°C) TO 220°F (105°C)
MINIMUM INSTALLATION TEMP:	32°F (0°C)
WEIGHT:	.04540 oz. / 1.31 grams
BUNDLE DIAMETER:	1.59mm - 44mm
MOUNTING:	1/4" DIA.HOLE IN 1/8" MAX.THICK PANEL
TOOLS:	12001 - HAND INSTALLATION TOOL 12500 - PNEUM. INSTALLATION TOOL
TOOL TENSION SETTING:	6-8
PACKAGED IN:	1000/BAG, 5000/CASE



FASTENER DIVISION
 FITCHBURG, MA 01420 U.S.A.
 TEL. 1-800-225-5913
 MA. 978-353-8157

NOTE: THESE CABLE TIES ARE
 PLENUM RATED AND HAVE A
 FLAMMABILITY RATING OF V-2



DESCRIPTION:

7.5" CABLE TIE, STANDARD,
 PUSH MOUNT

APPROVAL:

Q.A.:

Sandra Boyle 10/10/14

STOCK NO.

08445-0

REV
 M